

Contents

1. About this document

1.1. Function	4
1.2. Target group.....	4
1.3. Symbolism used.....	4

2. For your safety

2.1. Authorized personnel	5
2.2. Appropriate use.....	5
2.3. Warning about misuse	5
2.4. General safety instructions.....	5
2.5. CE conformity.....	5
2.6. Environmental instructions	5

3. Product description

3.1. Delivery configuration.....	6
3.2. Principle of operation	6
3.3. Adjustment	7
3.4. Storage and transport	7

4. Mounting

4.1. General instructions	8
4.2. Main dimensions of the instrument	8
4.3. Mounting procedure	9

5. Connecting

5.1. Preparing the connection	10
5.2. Connecting the Pt1000 sensor.....	11
5.3. Connecting the signal processing unit and the power supply	12
5.4. Put the instrument under supply voltage.....	12

6. Fault rectification

6.1. Fault finding.....	13
6.2. Repairing.....	13

7. Dismounting

7.1. Dismounting procedure.....	14
7.2. Disposal	14

8. Appendix

8.1. Technical specification	15
8.2. Application example.....	17

1. About this document

1.1. Function

This operating instructions manual has all the information you need for quick set-up and safe operation of DT1000 I4 Temperature Transmitter. Please read this manual before you start setup.

1.2. Target group

This operating instructions manual is directed to trained personnel. The contents of this manual should be made available to these personnel and put into practice by them.

1.3. Symbolism used



Information, tip, note

This symbol indicates helpful additional information.



Caution, warning, danger

This symbol informs you of a dangerous situation that could occur. Ignoring this cautionary note can impair the person and/or the instrument.

List



The dot set in front indicates a list with no implied sequence.

Action



This arrow indicates a single action.

Sequence



Numbers set in front indicate successive steps in a procedure.

2. For your safety

2.1. Authorized personnel



All operations described in this operating instructions manual must be carried out only by trained and authorized specialist personnel. For safety and warranty reasons, any internal work on the instruments must be carried out only by DATCON personnel.

2.2. Appropriate use

The DT1000 I4 is a temperature transmitter. Detailed information on the application range is available in **Chapter 3. Product description.**

2.3. Warning about misuse



Inappropriate or incorrect use of the instrument can give rise to application-specific hazards, or damage to system components through incorrect mounting or adjustment.

2.4. General safety instructions



The DT1000 I4 Temperature Transmitter is a high-tech instrument requiring the strict observance of standard regulations and guidelines.

The user must take note of the safety instructions in this operating instructions manual, the country-specific installation standards as well as all prevailing safety regulations and accident prevention rules.

2.5. CE conformity

The DT1000 I4 is in conformity with the provisions of the following standard:
MSZ EN 61326 (EMC)

2.6. Environmental instructions

Protection of the environment is one of our most important duties.

Please take note of the instructions written in the following chapters:

- Chapter **3.4. Storage and transport**
- Chapter **7.2. Disposal**

3. Product description

3.1. Delivery configuration

Delivered items

The scope of delivery encompasses:

- DT1000 I4
- documentation:
 - this operating instructions manual
 - certification
 - warranty

3.2. Principle of operation

Area of application

A DT1000 I4 Temperature Transmitter provide a 4-20 mA signal in proportional to the temperature measured by the Pt1000 temperature sensor connected to their input. The instrument is loop-powered from 4-20 mA signal. The sensor element can be connected in 3 or 4 wire measuring mode. In case of connecting the Pt1000 in 4 wire mode the wire and the connecting resistances have no effect on the measurement. In case of 3 wire mode the instrument is able to compensate the effect of the wire and connecting resistances if the PI+ and PI- resistances (wire+connecting) are equal to each other. The measuring current is about 80 μ A, so the self-heating effect of the sensor is negligible. In case of input fault (sensor or wire, short or broken) the output current is forced under 3.8 mA. There are recommended measuring ranges, see **8.1. Technical specification**, however customer specified ranges also available. Input and output is not isolated.

Operating principle



The instrument supplies measuring current for the Pt1000 sensor through the PI+, PI- connectors. The voltage drop on the sensor is led through the Pt+, Pt- connectors, filter-, protective- circuits to the amplifier and linearizing stage. The output of this stage controls the 4-20 mA output current according to the measuring range. The supply voltages and the reference voltages are generated from the 4-20 mA current loop.

Power supply

The instrument works from a 10-30 VDC supply voltage. The maximum supply current is 25 mA.

3.3. Adjustment

The DT1000 I4 doesn't need any adjustment.
After connected to the power supply it is ready to work.

3.4. Storage and transport

This instrument should be stored and transport in places whose climatic conditions are in accordance with chapter **8.1 Technical specification**, as described under the title: Environmental conditions.



The packaging of DT1000 I4 consist of environment-friendly, recyclable cardboard is used to protect the instrument against the impacts of normal stresses occurring during transportation. The corrugated cardboard box is made from environment-friendly, recyclable paper. The inner protective material is nylon, which should be disposed of via specialized recycling companies.

4. Mounting

4.1. General instructions



The instrument should be installed in a cabinet with sufficient IP protection, where the operating conditions are in accordance with chapter **8.1 Technical specification**, as described under the title: Operating conditions.

Mounting position



The instruments are designed in housing for mounting on TS-35 rail.

It is recommended to mount it in vertical position (horizontal rail position).

4.2. Main dimensions of the instrument

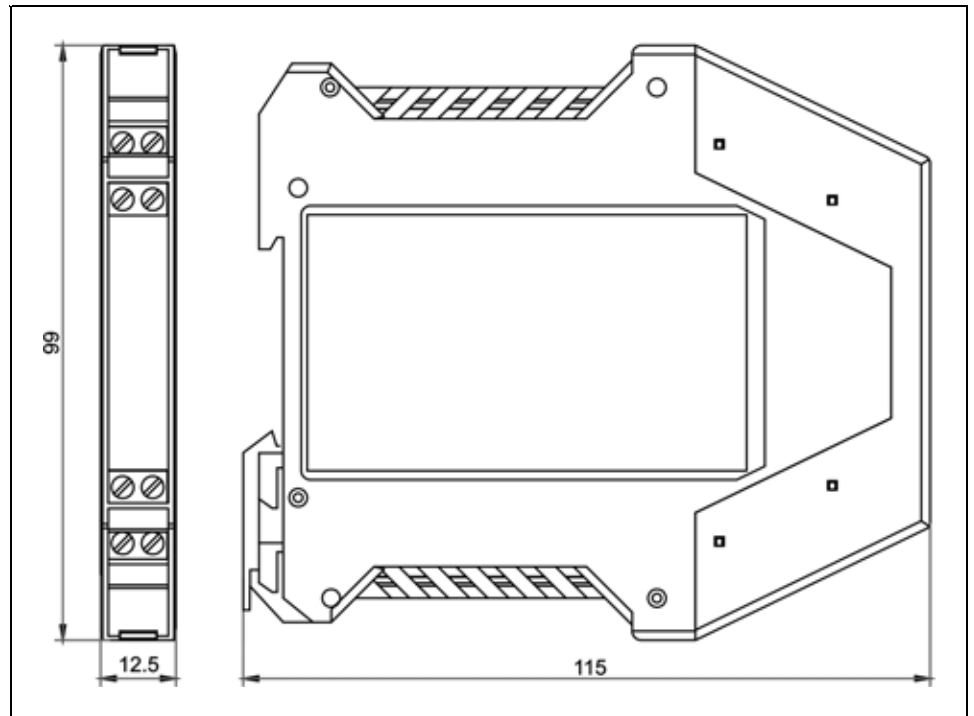

4.3. Mounting procedure

The following figure shows the mounting procedures (fixing on the rail):

Mounting on the rail

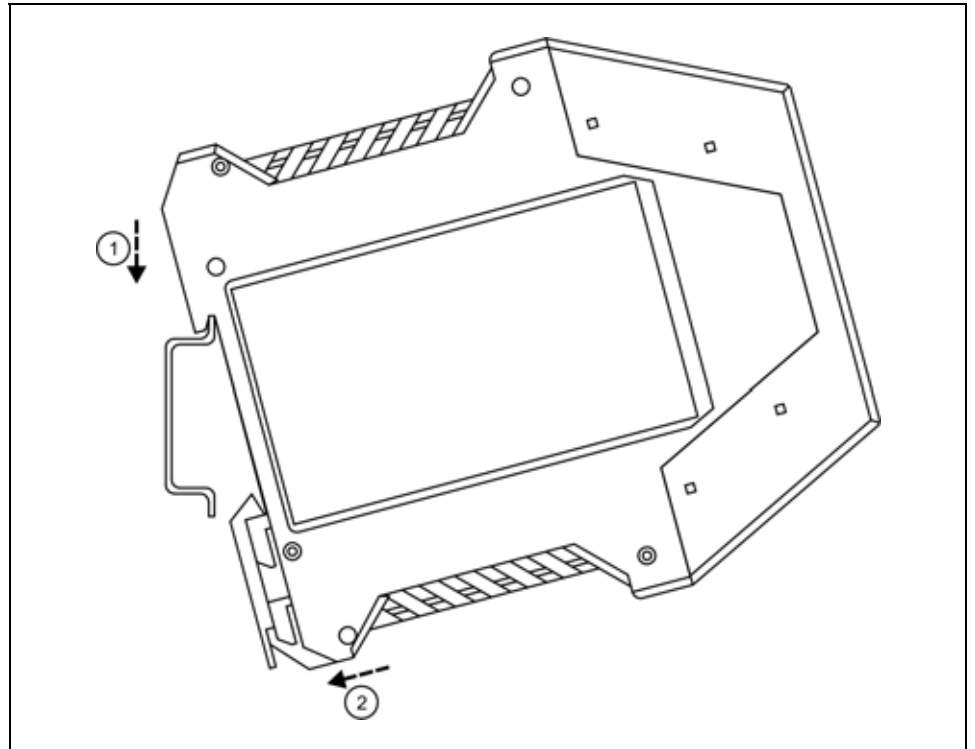

The mounting doesn't need any tool.

1. Tilt the instrument according to the figure; put the instrument's mounting hole onto the upper edge of the rail (figure step 1.).
2. Push the instrument's bottom onto the bottom edge of the rail (figure step 2.), you will hear the fixing assembly closing.
3. Check the hold of the fixing by moving the instrument firmly.

5. Connecting

5.1. Preparing the connection

Always observe the following safety instructions:



Select connection cable

- Use only a screwdriver with appropriate head.

Take note the suitability of the connecting cable (wire cross-section, insulation, etc.).

The wire cross-section should be 0.25-1.5 mm².

You may use either solid conductor or flexible conductor.

In case of using flexible conductor use crimped wire end.

Preparing cables

Prepare the cable for connection.

Strip approx. 8 mm insulation.



It is recommended to use screened cable especially for sensor connecting. In particular, make sure that no potential equalization currents flow over the cable screen. Ground the cable screen on the cabinet side.

It is an important rule that the measuring signal cables should be lead via a separate way than the control and power cables.

5.2. Connecting the Pt1000 sensor

The following figure shows the wiring plan, connecting the Pt1000 sensor:

Wiring plan, connecting the Pt1000 sensor in 4 wire mode
(see also “Application example”)

Wiring plan, connecting the Pt1000 sensor in 3 wire mode
(see also “Application example”)

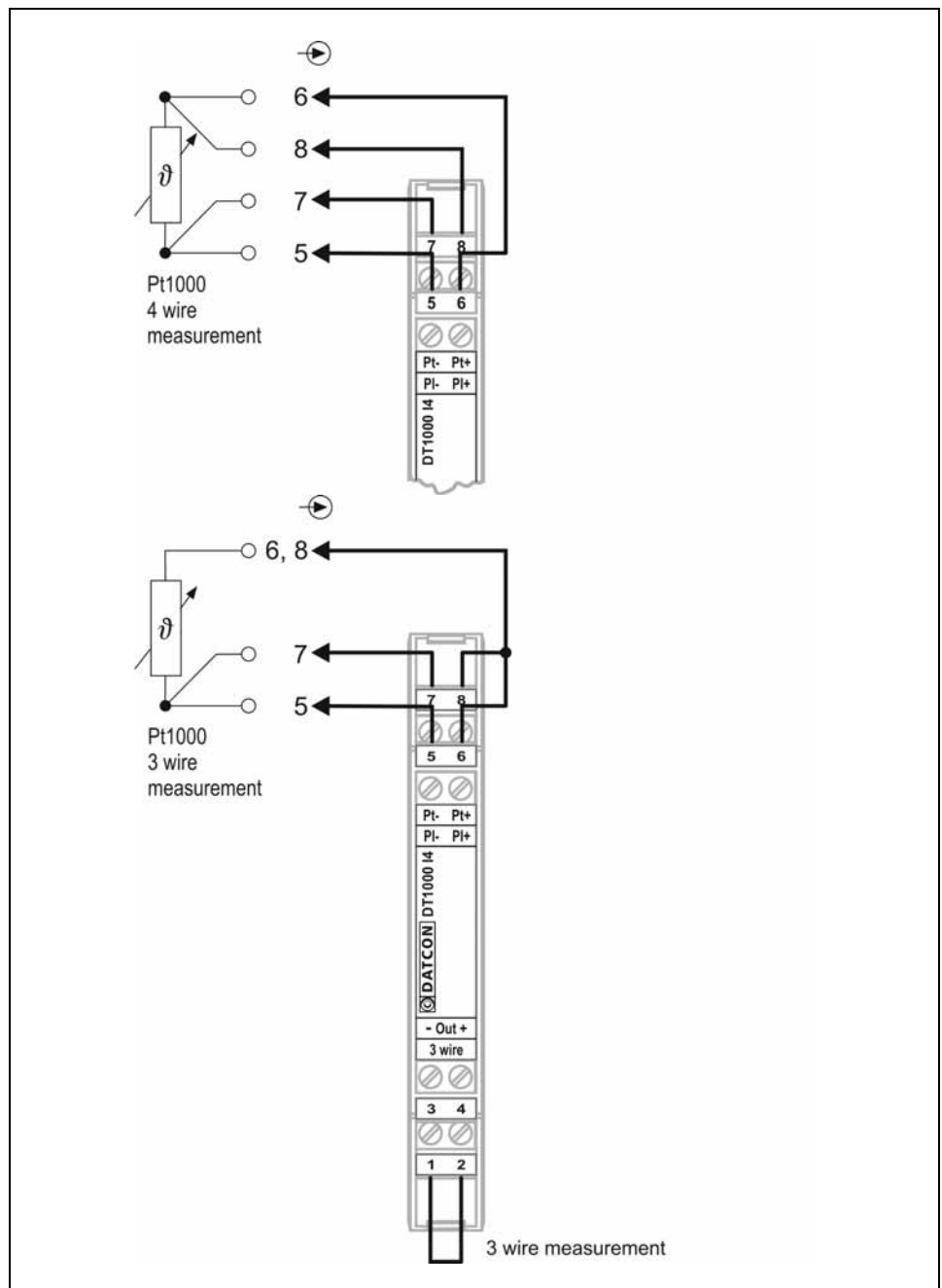

1. Loosen terminal screws.
2. Insert the wire ends into the open terminals according to the wiring plan.
3. Screw the terminal in.
4. Check the hold of the wires in terminals by pulling on them firmly.

5.3. Connecting the signal processing unit and the power supply

The following figure shows the wiring plan, connecting the signal processing unit:

Wiring plan, connecting the signal processing unit and the power supply

(see also “Application example”)

Be careful the polarity of the cables

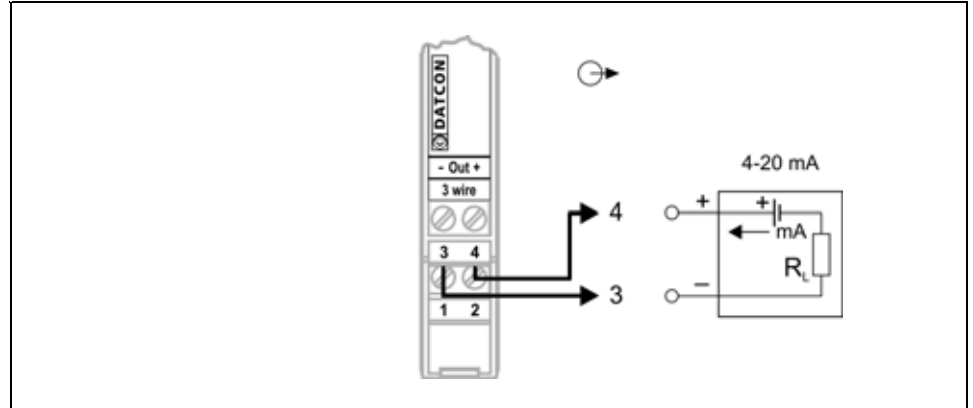

1. Loosen terminal screws.
2. Insert the wire ends into the open terminals according to the wiring plan.
3. Screw the terminal in.
4. Check the hold of the wires in terminals by pulling on them firmly.

Checking the connections

Check if the cables are connected properly (have you connected all the cables, have you connected to the right place, do not the cable-ends touch each other).
The connection is finished.

5.4. Put the instrument under supply voltage

Put the instrument under supply voltage

After you have completed the connections, put the instrument under supply voltage. If the connection is correct you can measure output current according to the measured temperature.

6. Fault rectification

6.1. Fault finding

The fault finding must be carried out by trained and authorized personnel only.



- There is no output signal → check the power supply. If the power supply is OK, the instrument is defective.
- The output current $< 3.8 \text{ mA}$ → check the Pt1000 sensor and it's connecting. If the Pt1000 sensor and it's connecting is OK, the instrument is defective.

When the result of fault finding is that the DT1000 I4 is defective, please call the manufacturer service department.

6.2. Repairing

There is no user repairable part inside the instrument. In accordance with **Chapter 2.1.:** **For safety and warranty reasons, any internal work on the instrument must be carried out by DATCON personnel.**



7. Dismounting

7.1. Dismounting procedure

Before dismounting take note the warnings written in **Chapter 5.1**.

The following figure shows the dismounting procedures:

Dismounting from the rail

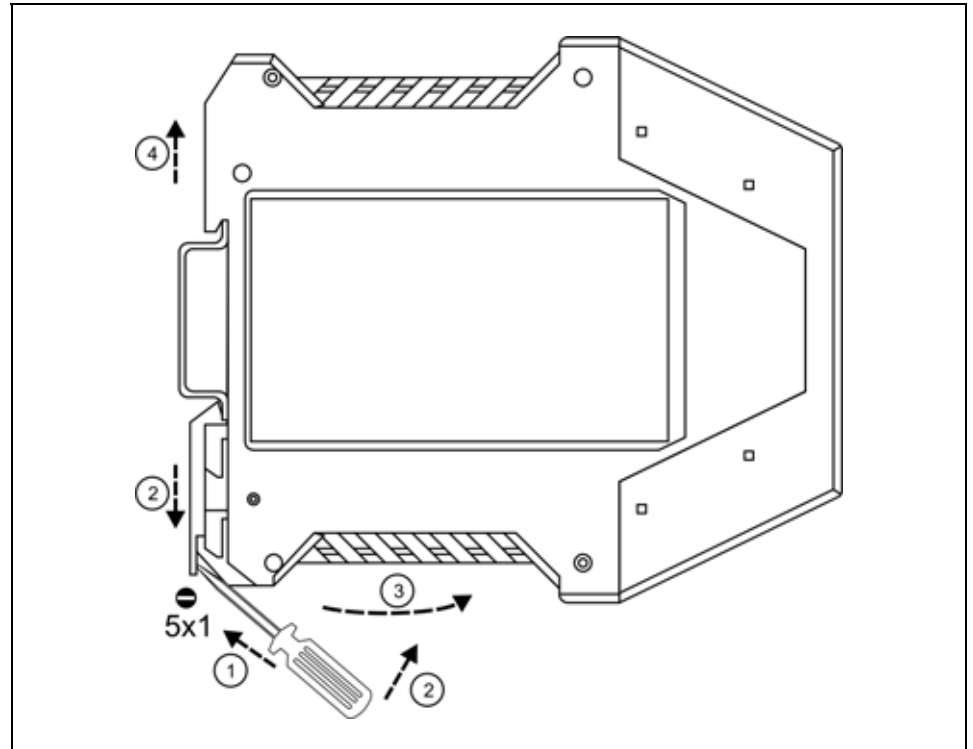

The dismounting procedure needs a screwdriver for slotted screws.

Before dismounting disconnect all wires.

1. Put the screwdriver end into the fixing assembly's hole (figure step 1.).
2. Lift the screwdriver handle until it possible to open the fixing assembly (figure step 2.).
3. Keeping the screwdriver in this position lift the instrument bottom from the bottom edge of the rail (figure step 3.).
4. Lift the whole instrument (you may put out the screwdriver) (figure step 4.), as far as the instrument will be free.

7.2. Disposal

According with the concerning EU directive, the manufacturer undertakes the disposal of the instrument that are manufactured by it and intended to be destroyed. Please deliver it in contamination-free condition to the site of the Manufacturer or to a specialized recycling company.

8. Appendix

8.1. Technical specification

Input parameters:

Input signal:	the resistance of Pt1000 sensor
Wiring:	four or three wire
Measuring current:	80 μ A (at 1000 ohm sensor resistance)
Power dissipation on Pt1000:	2,5 mW (max.)
Wire resistance:	100 ohm (max.)
Sensor fault signaling (broken or short):	$I_{out} < 3.8$ mA

Measuring ranges*:

Start points (°C)	Measuring ranges (°C)					
	50	100	200	400	600	800
-200	-200 - -150	-200 - -100	-200 - 0	-200 - 200	-200 - 400	-200 - 600
-100	-100 - -50	-100 - 0	-100 - 100	-100 - 300	-100 - 500	-
0	0 - 50	0 - 100	0 - 200	0 - 400	0 - 600	-
100	100 - 150	100 - 200	100 - 300	100 - 500	-	-
200	200 - 250	200 - 300	200 - 400	200 - 600	-	-
300	300 - 350	300 - 400	300 - 500	-	-	-
400	400 - 450	400 - 500	400 - 600	-	-	-
500	500 - 550	500 - 600	-	-	-	-

* Other ranges on customer request are also available

Output parameters:

Output signal:	4-20 mA
Overloading:	>22 mA
Error:	< 0.2 °C + 10 μ A (Ta: 23 °C \pm 2 °C) < 0.6 °C + 50 μ A (Ta: 0-60 °C)
Linearizing error:	0.1 °C (0-200 °C) 0.3 °C (0-600 °C)
Supply-voltage effect:	practically zero
Power supply:	10 - 30 VDC
Current limit:	~ 25 mA

Ambient conditions:

Operating temperature range:	0-60 °C (-20 - +60 °C on request)
Storage temperature range:	-20 - +70 °C
Relative humidity:	90% (max., non condensing)
Place of installation:	cabinet

Electromagnetic compatibility (EMC):

Accordance with the standard MSZ EN 61326

Immunity: -B- criterion

Noise emission: -A- class

General data:

Housing:	TS-35 rail mounting housing material: polyamide PA6.6
Connection:	screw terminal
Connecting cable:	2.5 mm ² (max.)
Dimensions:	12.5 x 99 x 115 mm (width x height x depth)
Weight:	0.15 kg
Protection:	IP 20

The Manufacturer maintains the right to change technical data.

8.2. Application example

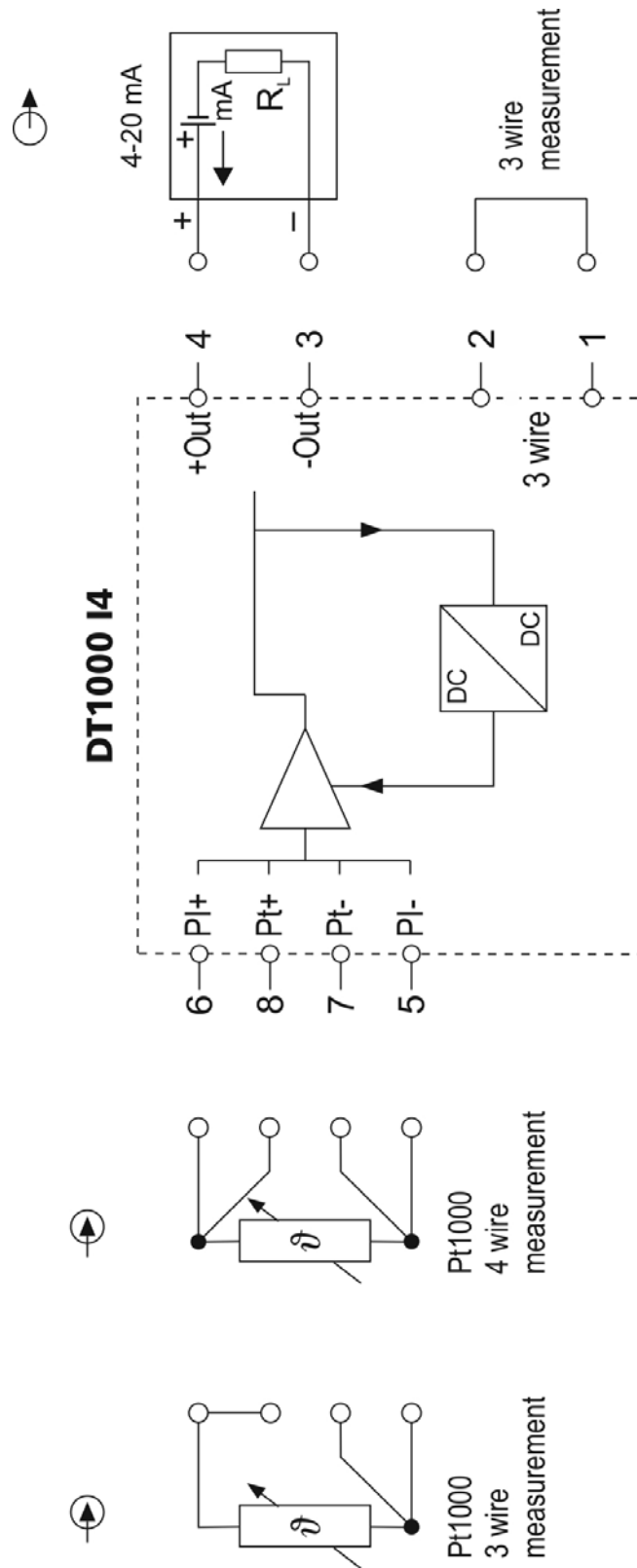

1148 Budapest, Fogarasi út 5. 27. ép. HUNGARY

Tel.: +(361) 460-1000 Fax: +(361) 460-1001 www.datcon.hu



INDUSTRIAL MEASUREMENT