

DT1102 INV (PS)

Switch Configurable I/O Galvanic Isolator (with inverse transfer characteristic)

Operating Instructions

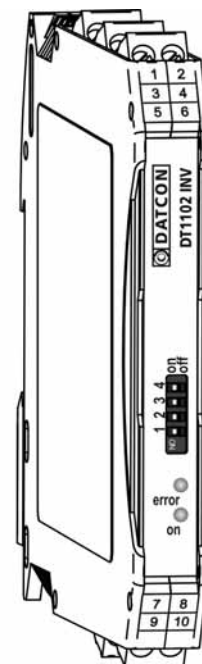

Contents

1. About this document

1.1. Function.....	4
1.2. Target group.....	4
1.3. Symbolism used.....	4

2. For your safety

2.1. Authorized personnel.....	5
2.2. Appropriate use.....	5
2.3. Warning about misuse.....	5
2.4. General safety instructions.....	5
2.5. CE conformity.....	5
2.6. Environmental instructions.....	5

3. Product description

3.1. Delivery configuration.....	6
3.2. Type designation.....	6
3.3. Operating principle.....	7
3.4. Indicators, configuration switches.....	9
3.5. Input/output signal selection.....	10
3.6. Storage and transport.....	11

4. Mounting

4.1. General instructions.....	12
4.2. Main dimensions of the instrument.....	12
4.3. Mounting procedure.....	13

5. Connecting

5.1. Preparing the connection.....	14
5.2. Connecting active output current source to the input.....	15
5.3. Connecting 4-20 mA two wire (passive) transmitter to the input.....	16
5.4. Connecting voltage source to the input.....	17
5.5. Connecting current output to the signal processing unit.....	18
5.6. Connecting voltage output to the signal processing unit.....	19
5.7. Connecting instrument to the power supply.....	20

6. First „power on”, front panel indicators

6.1. First „power on”.....	21
6.2. Front panel Indicators.....	21

7. Fault rectification

7.1. Fault finding.....	22
7.2. Repairing.....	22

8. Dismounting

8.1. Dismounting procedure.....	23
8.2. Disposal.....	23

9. Appendix

9.1. Technical specification	24
9.2. Application example	26

1. About this document

1.1. Function

This operating instructions manual has all the information you need for quick set-up and safe operation of DT1102 INV (PS)
Please read this manual before you start setup.

1.2. Target group

This operating instructions manual is directed to trained personnel.
The contents of this manual should be made available to these personnel and put into practice by them.

1.3. Symbolism used



Information, tip, note

This symbol indicates helpful additional information.



Caution, warning, danger

This symbol informs you of a dangerous situation that could occur.
Ignoring this cautionary note can impair the person and/or the instrument or its environ.

List

- The dot set in front indicates a list with no implied sequence.

Action

- This arrow indicates a single action.

Sequence

- 1 Numbers set in front indicate successive steps in a procedure.

2. For your safety

2.1. Authorized personnel



All operations described in this operating instructions manual must be carried out only by trained and authorized specialist personnel. For safety and warranty reasons, any internal work on the instruments must be carried out only by DATCON personnel.

2.2. Appropriate use

The DT1102 INV (PS) is an instrument for industrial use. Detailed information on the application range is available in chapter **3. Product description**.

2.3. Warning about misuse



Inappropriate or incorrect use of the instrument can give rise to application-specific hazards, or damage to system components through incorrect installing or adjustment.

2.4. General safety instructions



Using the DT1102 INV (PS) requiring the strict observance of standards, regulations and guidelines.

The user must take note of the safety instructions in this operating instructions manual, the country-specific installation standards as well as all prevailing safety regulations and accident prevention rules.

2.5. CE conformity

The DT1102 INV (PS) is in conformity with the provisions of the following standards:

- EN IEC 61326-1 (EMC)
- EN 61010-1 (Safety)
- EN 61558-1 (Safety)

2.6. Environmental instructions

Protection of the environment is one of our most important duties. Please take note of the instructions written in the following chapters:

- Chapter **3.6. Storage and transport**
- Chapter **8.2. Disposal**

3. Product description

3.1. Delivery configuration

Delivered items

The scope of delivery encompasses:

- DT1102 INV (PS)
- tool for switch setting
(in case of shipping more instrument only one tool is enclosed)
- documentation:
this operating instructions manual
certification
warranty

3.2. Type designation

DT1102 INV

24 VDC power supply

DT1102 INV PS

230 V AC/DC power supply

Area of application

3.3. Operating principle

The DT1102 INV (PS) Switch Configurable I/O Galvanic Isolator (with inverse transfer characteristic) provide signal transmission and conversion between transmitters and signal processing units.

The instruments feature complete 3-way isolation: the input, the output and the power supply are isolated from each other.

The instrument has two inputs:

1. 0(4)-20 mADC current or*
2. 0(2)-10 VDC voltage*

and two outputs:

1. 0(4)-20 mADC current or*
2. 0(2)-10 VDC voltage.

* only one input and one output are active together

The input/output ranges are switch selectable.

The DT1102 INV (PS) - providing a 20 VDC, 20 mA supply on the input – for supplying 4-20 mA passive transmitters.

The front panel LED indicators provide information about the operating status of the device. (power on state, error states)

The diagram below illustrates the inverse function transfer characteristic for the 4-20 mA / 20-4 mA signal type:

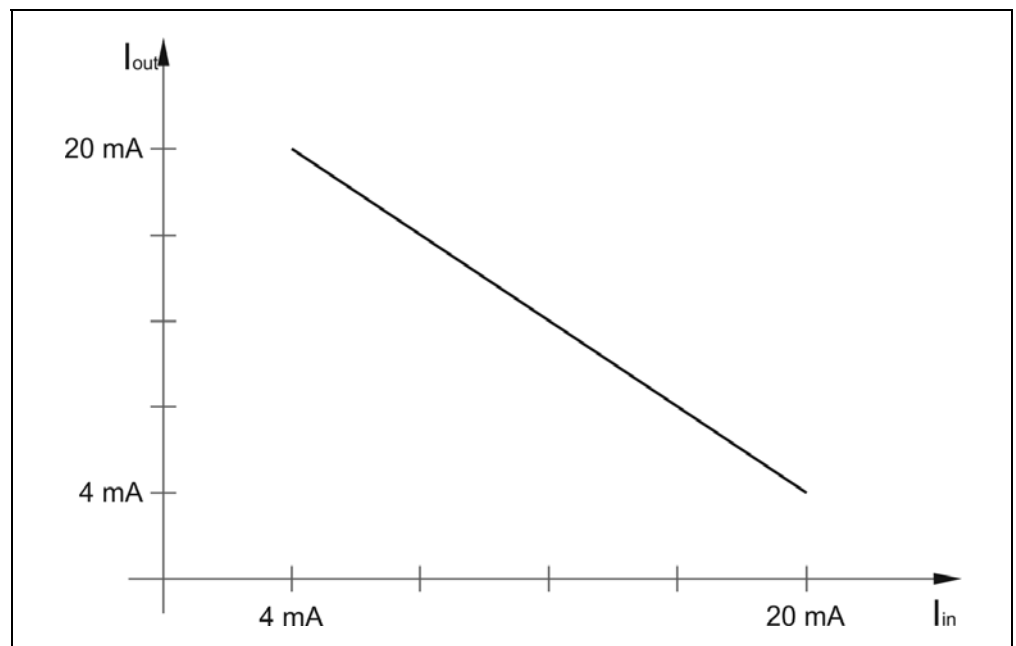

Principle of operation

The input current flows through the measuring resistor or the input voltage divides through the attenuator. This voltage drop is led to a 24 bit A/D converter. The digital output signal of the A/D converter is processed by a microcontroller.



The microcontroller performs signal processing according to the settings, implements the inverse function-based output characteristic, and then converts the measured value into a pulse-width modulated signal. This signal is transmitted via an optocoupler to the input of the output-side circuit. This circuit converts the signal back into an analog form, which, depending on the configuration, appears at the outputs as either current or voltage.

The internal power supplies are generated by an isolated dual output DC/DC converter, using planar transformer technology.

Power supply

The instrument has two different power supply version:

DT1102 INV:

Power supply: 24 VDC $\pm 10\%$

DT1102 INV PS:

Power supply: 230 V AC/DC $\pm 10\%$

3.4. Indicators, configuration switches

The following figure shows the indicators and the configuration switches on the DT1102 INV (PS) front panel.

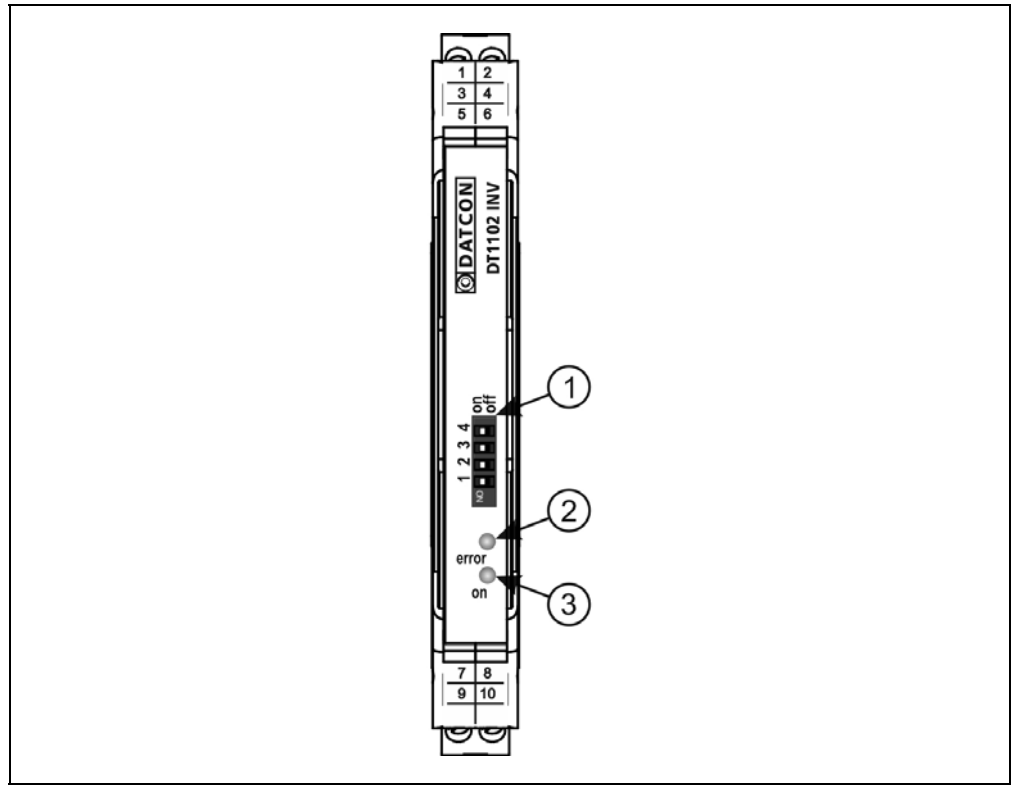

- (1) configuration switches for selection input/output ranges
- (2) red „error” indicator shows the error states
- (3) green „on” indicator shows the power on state

3.5. Input/output signal selection

Four different input/output signal range can be selected with the front panel switches:

0-20 mA, 4-20 mA, 0-10 V, 2-10 V

Default setting: 0-20 mA input, 0-20 mA output
(all switches are in „off” state).

The following figure shows the input/output signal range selection table:

	INPUT		OUTPUT		
	1	2	3	4	
0-20 mA	off	off	off	off	0-20 mA
4-20 mA	on	off	on	off	4-20 mA
0-10 V	off	on	off	on	0-10 V
2-10 V	on	on	on	on	2-10 V

The following figure shows steps of setting:

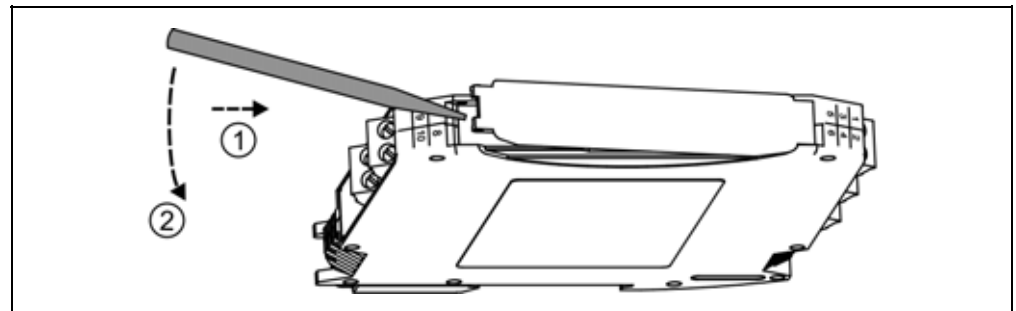

1. Take the instrument in hand according to the figure
2. Open the front panel cover with the enclosed tool according to the figure

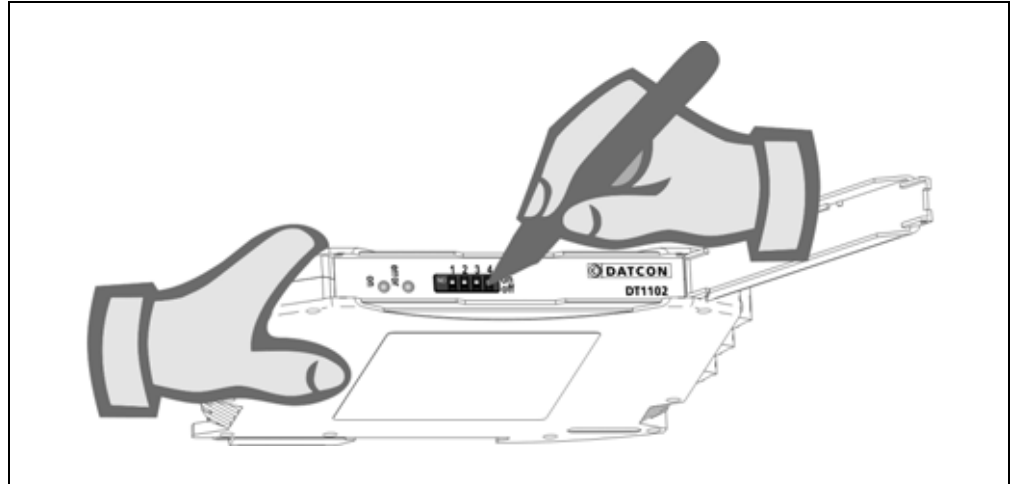

3. Set the configuration switches according to the signal range selection table
4. Close the front panel cover



Do not use other tool than the enclosed one because you may cause injury either to switches or to front panel!

3.6. Storage and transport

This instrument should be stored and transport in places whose climatic conditions are in accordance with chapter **9.1. Technical specification**, as described under the title: Environmental conditions.

The packaging of DT1102 INV (PS) consist of environment-friendly, recyclable cardboard is used to protect the instrument against the impacts of normal stresses occurring during transportation. The corrugated cardboard box is made from environment-friendly, recyclable paper. The inner protective material is nylon, which should be disposed of via specialized recycling companies.

4. Mounting

4.1. General instructions



Mounting position

The instrument should be installed in a cabinet with sufficient IP protection, where the operating conditions are in accordance with chapter 9.1. **Technical specification**, as described under the title: Operating conditions.

The DT1102 INV (PS) is built in a plastic housing, for mounting on TS-35 rail. Suggested mounting position: vertical (horizontal rail position).

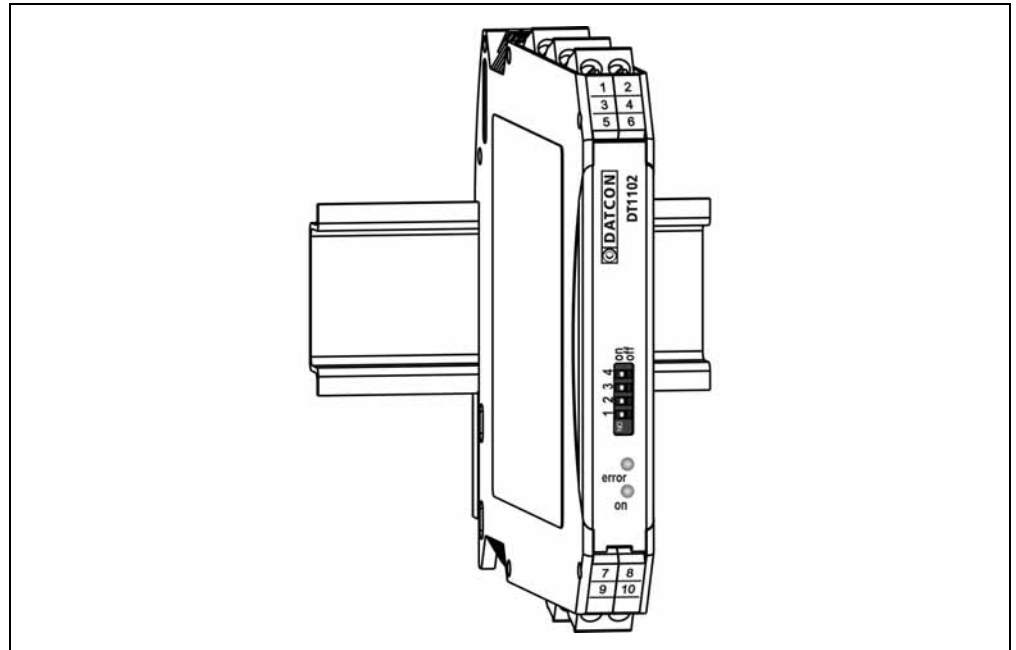

4.2. Main dimensions of the instrument

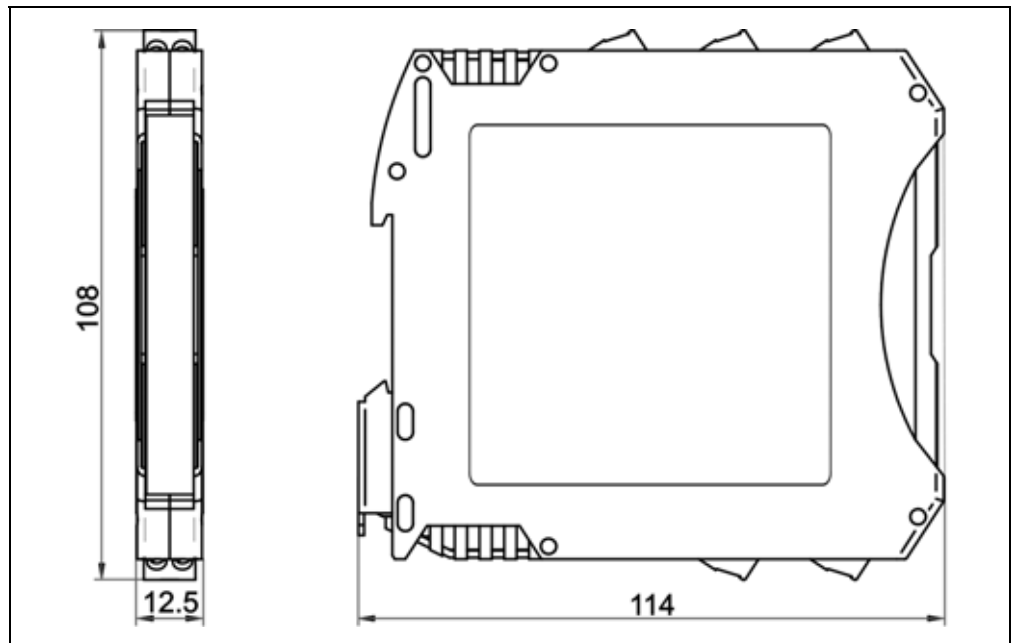

4.3. Mounting procedure

The following figure shows the mounting procedures (fixing on the rail):

Mounting on the rail

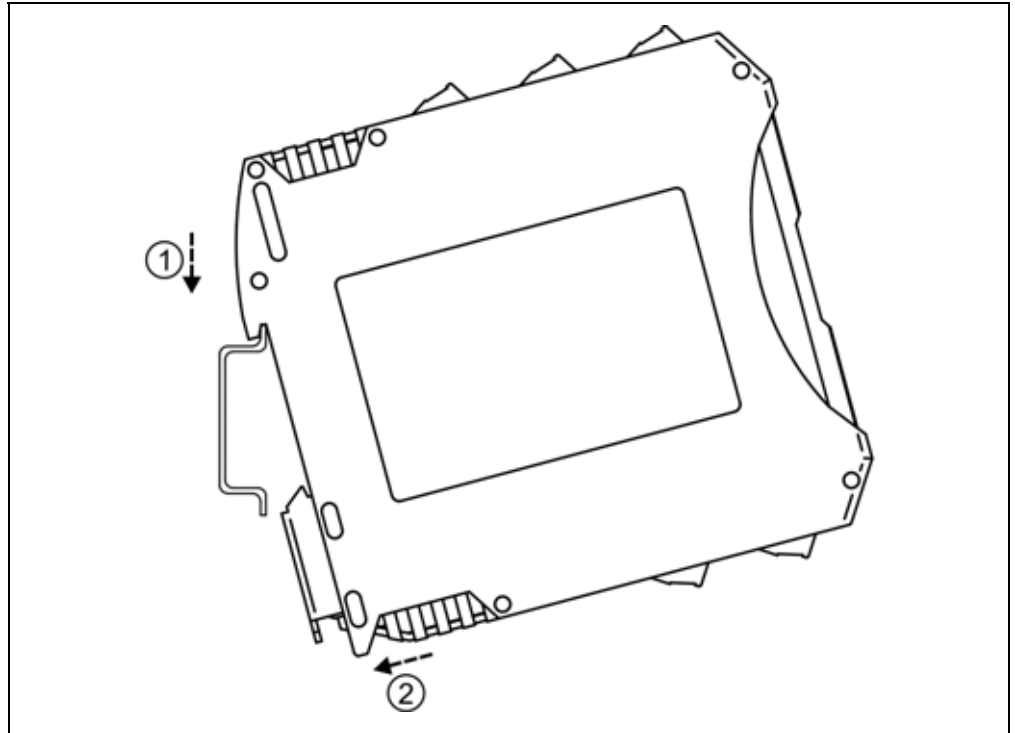

The mounting doesn't need any tool.

1. Tilt the instrument according to the figure; put the instrument's mounting hole onto the upper edge of the rail (figure step 1.).
2. Push the instrument's bottom onto the bottom edge of the rail (figure step 2.), you will hear the fixing assembly closing.
3. Check the hold of the fixing by moving the instrument firmly.

5. Connecting

5.1. Preparing the connection

Always observe the following safety instructions:



- The connection must be carried out by trained and authorized personnel only!
- Connect or disconnect only in the complete absence of line voltage
- You should take note the data concerning on the overcurrent protection in installation.
- Use only a screwdriver with appropriate head

Select connection cable

Take note the suitability of the connecting cable (wire cross-section, insulation, screening, etc.). You may use either solid conductor or flexible conductor. In case of using flexible conductor use crimped wire end.



The instrument can be connected with standard two-wire cable without screen. If electromagnetic interference is expected which is above the test values of the correspondent standard for industrial areas (e.g. high power frequency drives are working in the area) screened cable should be used. Ground the cable shield on the cabinet side. Always lead the signal cables on a separate path from the control and power cables!

Preparing cables

Prepare the cable for the connection. Strip approx. 8 mm insulation. In case of using flexible conductor use crimped wire end.

5.2. Connecting active output current source to the input

The following figure shows connecting active output current source to the input:

Wiring plan, connecting active output current source
(see also “Application example”)

Be careful the polarity of the cables

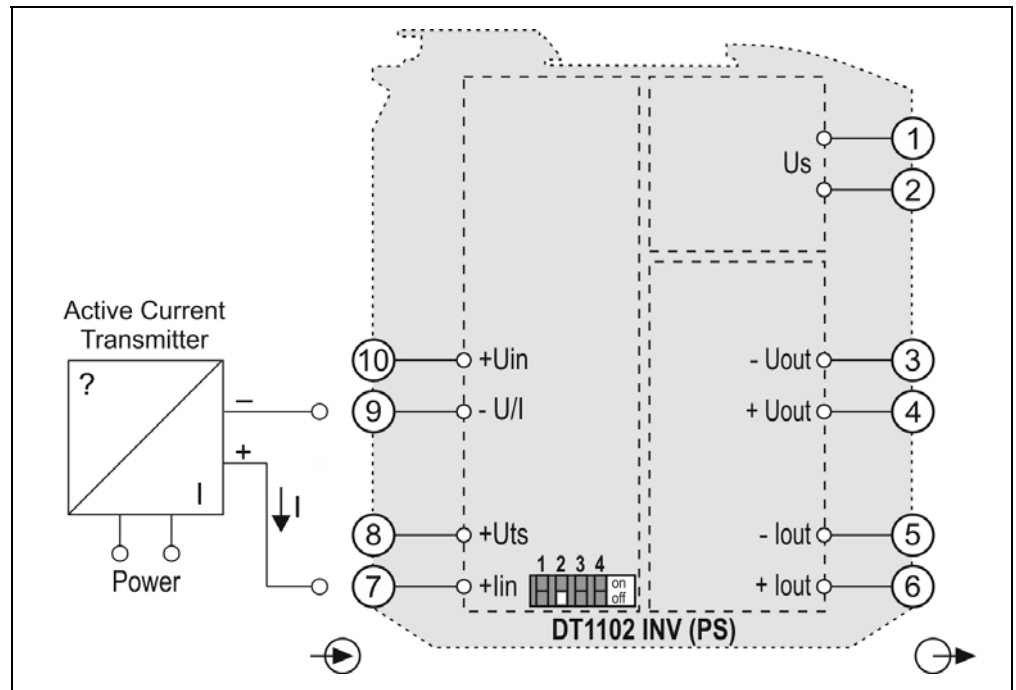

1. Loosen terminal screws.
2. Insert the wire ends into the open terminals according to the wiring plan.
3. Screw the terminal in.
4. Check the hold of the wires in terminals by pulling on them firmly.

Terminal (8) and (10) are out of use!

Checking the connections

Check if the cables are connected properly (have you connected all the cables, have you connected to the right place, do not the cable-ends touch each other).

5.3. Connecting 4-20 mA two wire (passive) transmitter to the input

The following figure shows connecting 4-20 mA two wire (passive) transmitter to the input:

Wiring plan, connecting 4-20 mA two wire transmitter (see also "Application example")

Be careful the polarity of the cables

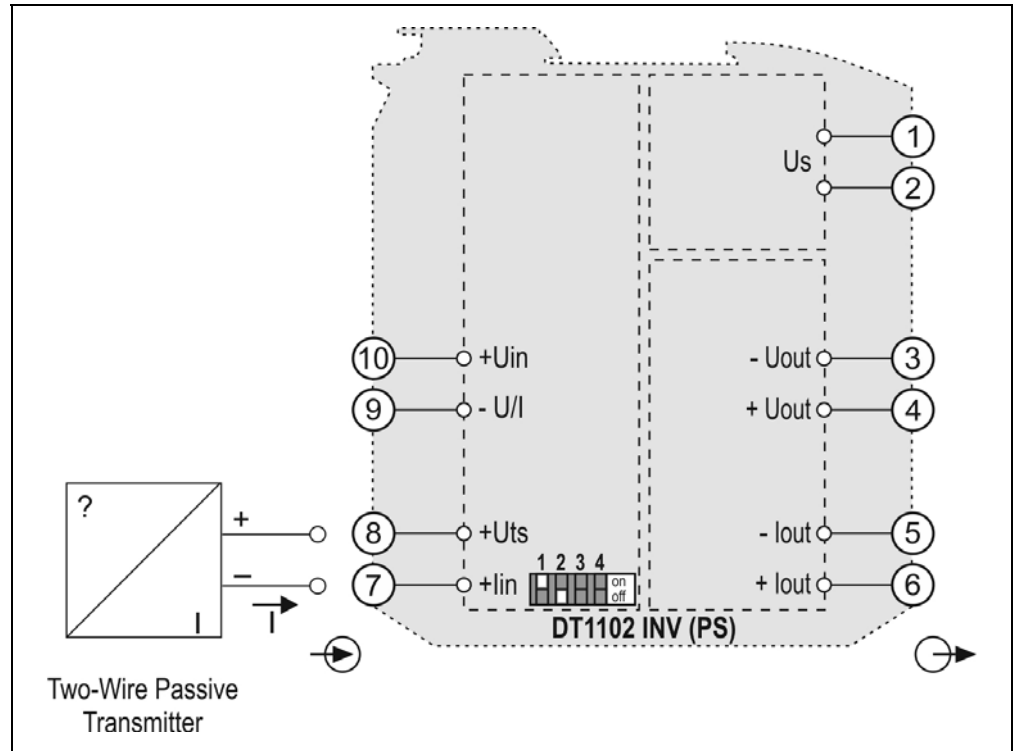

1. Loosen terminal screws.
 2. Insert the wire ends into the open terminals according to the wiring plan.
 3. Screw the terminal in.
 4. Check the hold of the wires in terminals by pulling on them firmly.
- Terminal (9) and (10) are out of use!

Checking the connections

Check if the cables are connected properly (have you connected all the cables, have you connected to the right place, do not the cable-ends touch each other).

5.4. Connecting voltage source to the input

The following figure shows connecting voltage source to the input:

Wiring plan, connecting voltage source

(see also “Application example”)

Be careful the polarity of the cables

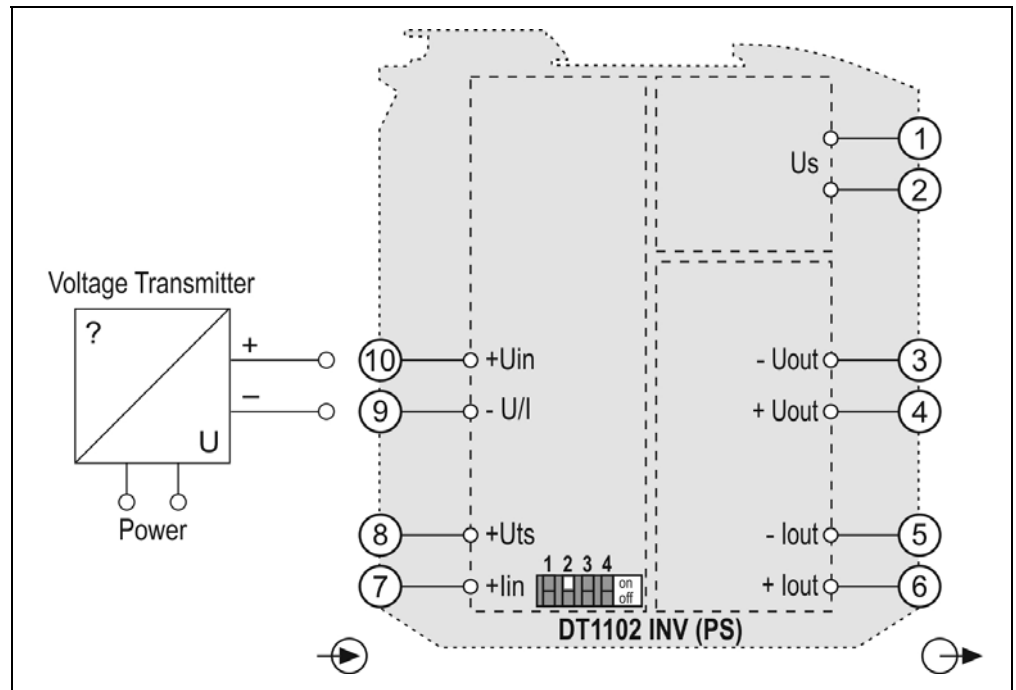

1. Loosen terminal screws.
 2. Insert the wire ends into the open terminals according to the wiring plan.
 3. Screw the terminal in.
 4. Check the hold of the wires in terminals by pulling on them firmly.
- Terminal (8) and (7) are out of use!

Checking the connections

Check if the cables are connected properly (have you connected all the cables, have you connected to the right place, do not the cable-ends touch each other).

5.5. Connecting current output to the signal processing unit

The following figure shows connecting current output to the signal processing unit:

Wiring plan, connecting current output

(see also “Application example”)

Be careful the polarity of the cables

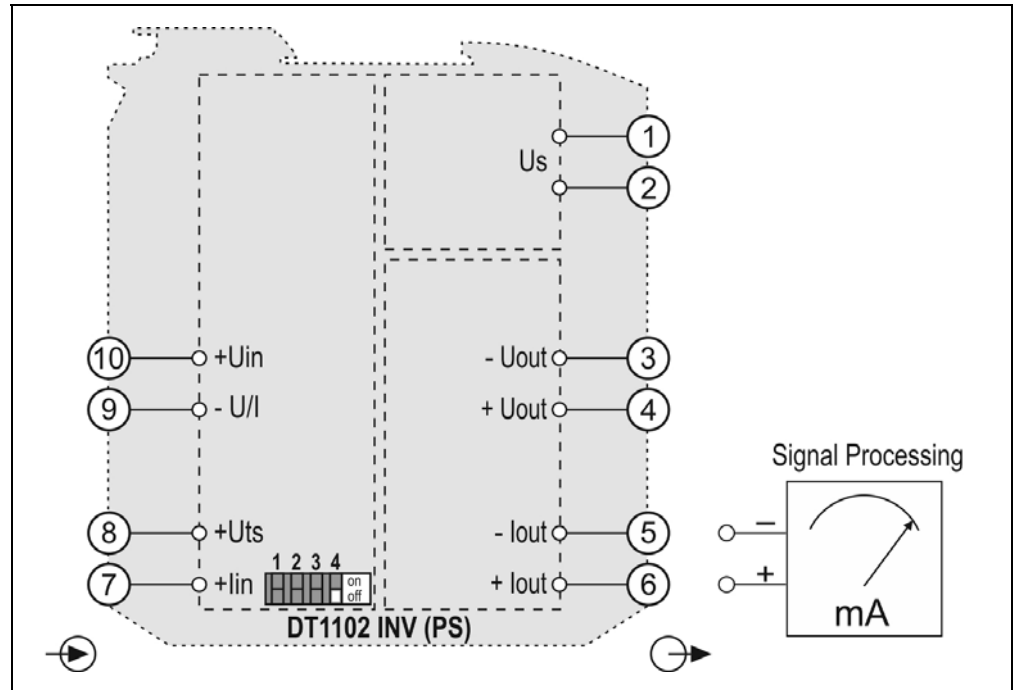

1. Loosen terminal screws.
 2. Insert the wire ends into the open terminals according to the wiring plan.
 3. Screw the terminal in.
 4. Check the hold of the wires in terminals by pulling on them firmly.
- Terminal (3) and (4) are out of use!

Checking the connections

Check if the cables are connected properly (have you connected all the cables, have you connected to the right place, do not the cable-ends touch each other).

5.6. Connecting voltage output to the signal processing unit

The following figure shows connecting current output to the signal processing unit:

Wiring plan, connecting voltage output

(see also “Application example”)

Be careful the polarity of the cables

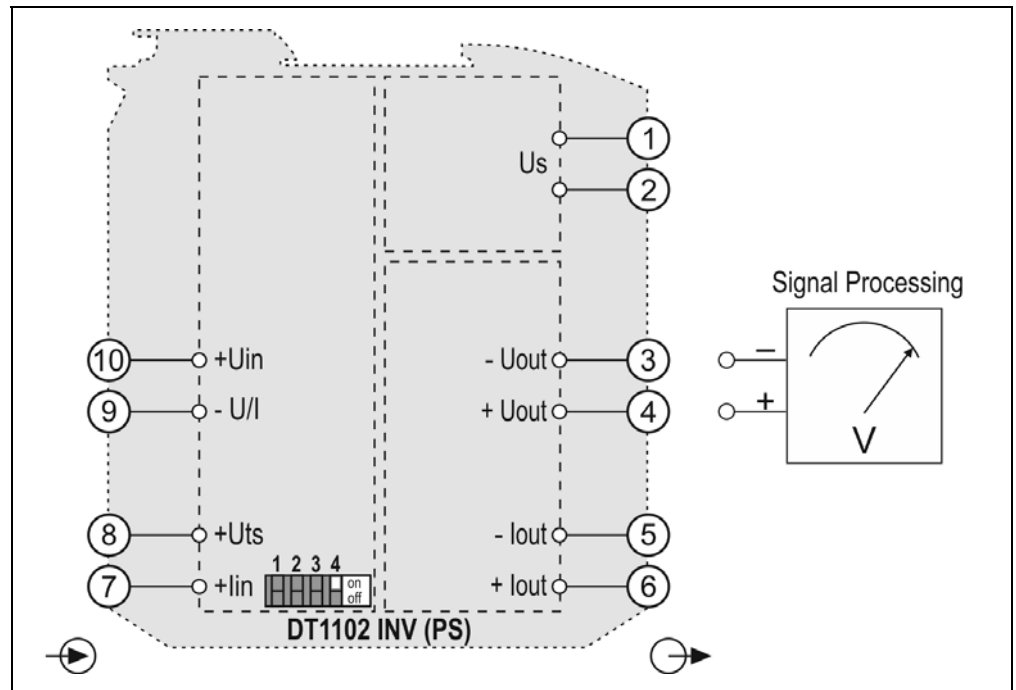

1. Loosen terminal screws.
 2. Insert the wire ends into the open terminals according to the wiring plan.
 3. Screw the terminal in.
 4. Check the hold of the wires in terminals by pulling on them firmly.
- Terminal (5) and (6) are out of use!

Checking the connections

Check if the cables are connected properly (have you connected all the cables, have you connected to the right place, do not the cable-ends touch each other).

5.7. Connecting instrument to the power supply

The following figure shows connecting the instrument to the power supply:

Wiring plan, connecting the power supply

(see also “Application example”)

The polarity of the cables is indifferent

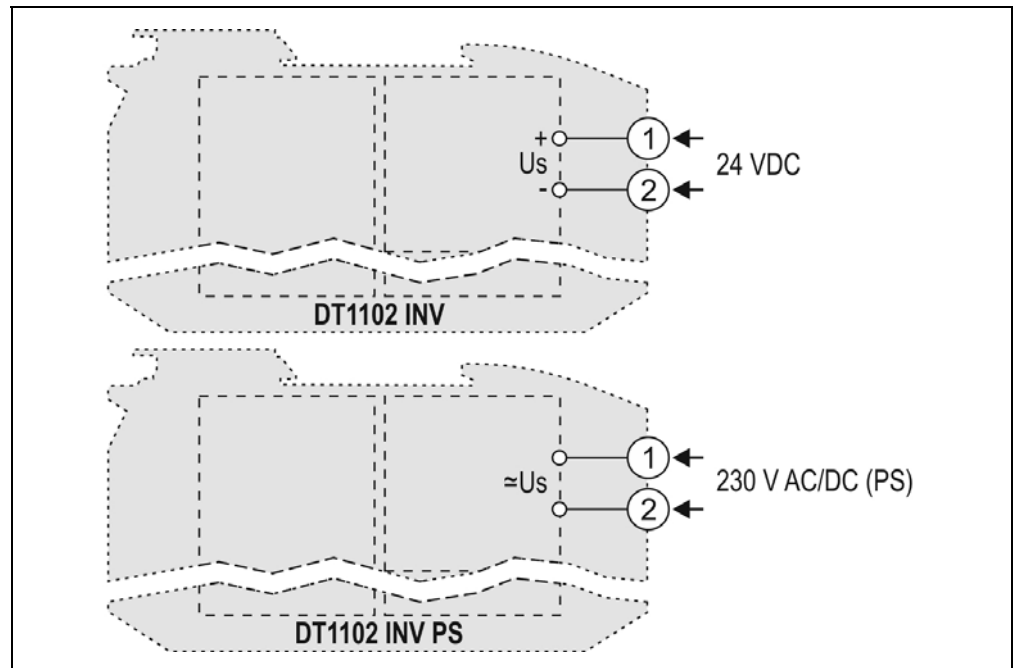

1. Before connecting check that the supply voltage correspond with the supply voltage written on the data label. When the instrument type designation ends with „PS” then the power supply terminal coloured black.
2. Connect only in the complete absence of line voltage
3. Loosen terminal screws.
4. Insert the wire ends into the open terminals according to the wiring plan.
5. Screw the terminal in.
6. Check the hold of the wires in terminals by pulling on them firmly.

Checking the connections

Check if the cables are connected properly (have you connected all the cables, have you connected to the right place, do not the cable-ends touch each other).

6. First „power on”, front panel indicators

6.1. First „power on”

After you have completed the connections, put the instrument under supply voltage. If the connection is correct green “on” indicator lights, red “error” indicator dark and you can measure the expected current or voltage on the output.



Warning! Insufficient setting or connection may cause improper working of the instrument or in certain situation may cause impairment of the instrument!

6.2. Front panel Indicators

- **In normal (working) mode:**

Green „on” indicator lights, red „error” indicator dark.

- **Under configuration (switch setting):**

Green „on” indicator goes out 1, 2, 3, 4 times according to the number of the switch which state was changed.

- **In error state:**

Green „on” indicator lights, red „error” indicator flashes periodically according to the error type:

1 flash/sec + break: the instrument is defective

4 flash/sec + break: input out of range

5 flash/sec + break: output out of range

7. Fault rectification

7.1. Fault finding

The fault finding must be carried out by trained and authorized personnel only!

The improper working may be caused by the connected instruments, wrong settings or connection, defect of the power supply or defect of the instrument.



First check the settings. When the settings are OK continue fault finding:

- Green “on” indicator dark → check the power supply. If the power supply OK: the instrument is defective.
- Green “on” indicator lights, red “error” indicator flashes 1/sec periodically: the instrument is defective.
- Improper output signal → disconnect the signal processing unit from the output, check the input signal and the transmitter supply (when it is in use). If the input signal and the transmitter supply are OK: the instrument is defective.

When the result of fault finding is that the DT1102 INV (PS) is defective call the manufacturer service department.

7.2. Repairing

There is no user repairable part inside the instrument.



In accordance with Point 2.1.: **For safety and warranty reasons, any internal work on the instrument must be carried out only by DATCON personnel.**

8. Dismounting

8.1. Dismounting procedure

Before dismounting take note the warnings written in chapter 5.1.

Preparing the connection.

The following figure shows the dismounting procedures.



Dismounting from the rail

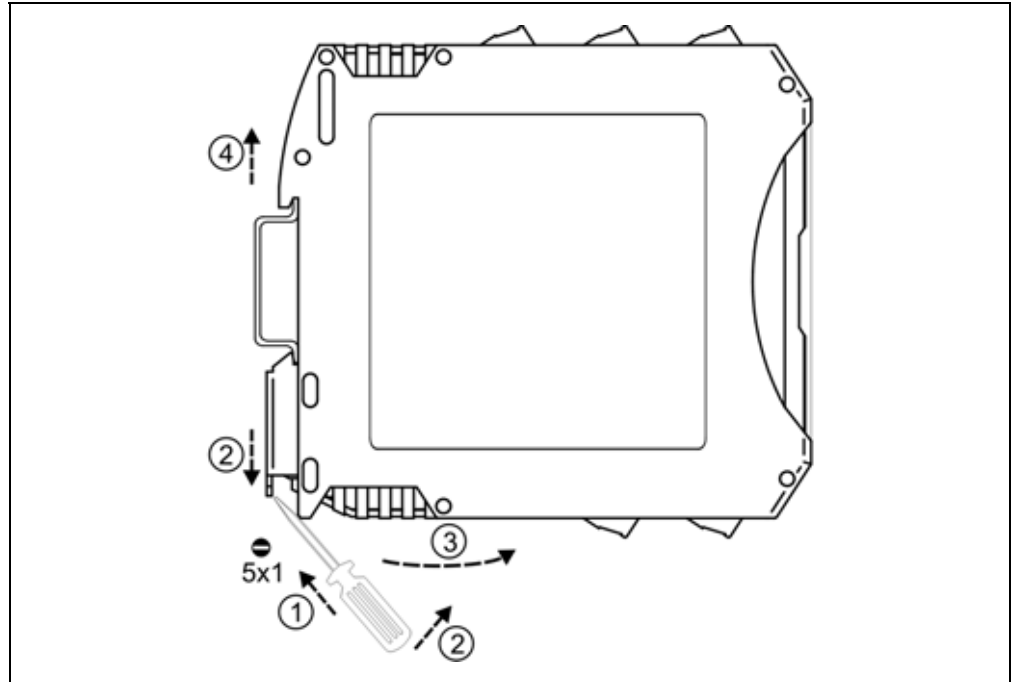

The dismounting procedure needs a screwdriver for slotted screws. Before dismounting disconnect all wires.

1. Put the screwdriver end into the fixing assembly's hole (figure step 1.).
 2. Lift the screwdriver handle until it possible to open the fixing assembly (figure step 2.).
 3. Keeping the screwdriver in this position lift the instrument bottom from the bottom edge of the rail (figure step 3.).
- Lift the whole instrument (you may put out the screwdriver) (figure step 4), the instrument will be free.

8.2. Disposal

According to the concerning EU directive, the manufacturer undertakes the disposal of the instrument that are manufactured by it and intended to be destroyed. Please deliver it in contamination-free condition to the site of the Manufacturer or to a specialized recycling company.

9. Appendix

9.1. Technical specification

Input parameters (current)

Input signal:	DC current
Ranges:	0-20 mA, 4-20 mA
Overload:	400 mA
Input resistance:	10 Ω

Input parameters (voltage)

Input signal:	DC voltage
Ranges:	0-10 V, 2-10 V
Overload:	100 V
Input resistance:	102 k Ω

Transmitter power supply

Voltage:	> 20 VDC @ 20 mA load
Overcurrent protection:	25 mA

Output parameters (current)

Output signal:	DC current
Ranges:	0-20 mA, 4-20 mA
Overdriving capability:	22.5 mA
Load resistance:	\leq 650 Ω
Output resistance:	> 3 M Ω

Output parameters (voltage)

Output signal:	DC voltage
Ranges:	0-10 V, 2-10 V
Overdriving ability:	11 V
Load resistance:	\geq 500 Ω
Output resistance:	< 0.5 Ω

Transfer parameters

Transfer characteristic:	Inverse function
Error of output @ 25 $^{\circ}$ C \pm 2 $^{\circ}$ C:	\pm 0.05%
Nonlinearity:	0.02% (max.)
Temperature coefficient:	typ. 25 ppm / $^{\circ}$ C; max. 50 ppm / $^{\circ}$ C
Supply-voltage effect:	practically zero
Settling time:	250 ms (90%) / 300 ms (99%)

Galvanic isolation

Working voltage:	250 Veff (between the input, the output and the power supply terminals)
Type test / routine test voltage:	4200 VDC (1 min) / 2500 VDC (1 min)
Capacity:	20 pF (between input, output, power supply terminals)
Protection class:	II. reinforced insulation
Leakage current:	0,005 mA (between input, output, power supply terminals)

Power supply

Supply voltage:	
DT1102	24 VDC $\pm 10\%$, 1.6 W
DT1102 PS	230 V AC/DC $\pm 10\%$, 3.8 VA (2.4 W)
Overvoltage class:	CAT II.
The overcurrent protection in installation:	4 A (B)

Ambient conditions

Operating temperature range:	0-50 °C *
Storage temperature range:	-20 - +70 °C
Relative humidity:	90% (max., non-condensing)
Place of installation:	cabinet
Mounting position:	vertical (horizontal rail position)

* -20 - +50 °C on request

Electromagnetic compatibility (EMC): In accordance with the standard EN IEC 61326-1

Conducted:	Limits for Class A equipments EN 55011	
Radiated:	Limits for Class A equipments EN 55011	
ESD:	4 kV/8 kV contact / air	-B- criteria
BURST:		
Analogue input	4 kV (5/50 ns, 5 kHz)	-A- criteria
Main supply input (PS)	2 kV (5/50 ns, 5 kHz)	-A- criteria
Analogue outputs	1 kV (5/50 ns, 5 kHz)	-A- criteria
SURGE:		
Analogue input	4 kV	-B- criteria
Main supply input (PS)	2 kV (line to ground)	-B- criteria
Analogue outputs	1 kV (line to ground)	-B- criteria
Conducted RF immunity:	3 Veff	-A- criteria
Conducted RF emission:	1 group, Class B	
Radiated RF immunity:	E=10 V/m	-A- criteria
Radiated RF emission:	1 group, Class B	
Power failure bypass:	20 ms @ 230 V AC/DC $\pm 10\%$	-A- criterion

General data

Housing:	TS-35 rail mounting housing material: polyamide PA6.6
Fireproof class:	V2-V0 / UL94
Connection:	pluggable screw-terminal
Connecting cable:	1.5 mm ² (max.)
Dimensions:	12.5 x 108 x 114 mm (width x height x depth)
Mass:	0.15 kg
Ingress Protection (EN 60529):	IP 20

The Manufacturer maintains the right to change technical data.

9.2. Application example

